

# Double Glazing Systems

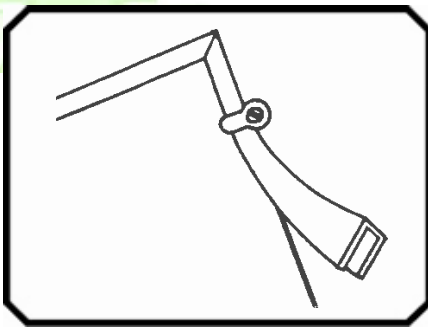

**ClipGlaze**

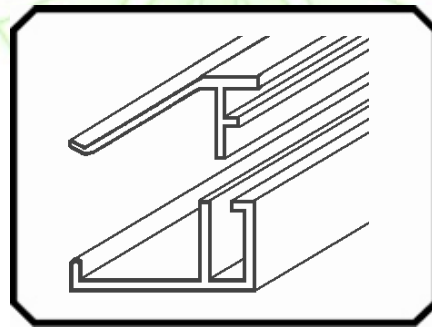

**EasyGlaze**

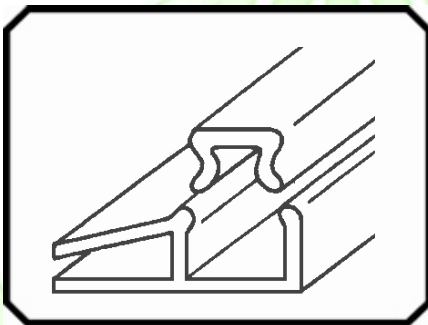

**SuperGlaze**

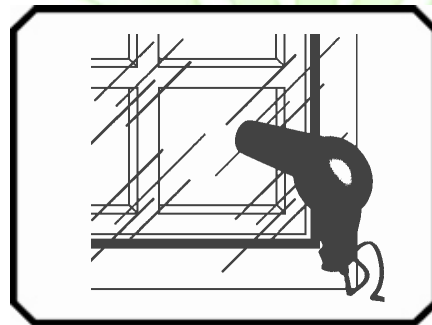

**FilmGlaze**

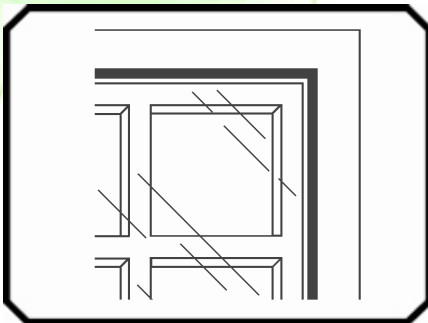

**Magnetglaze / Pro**

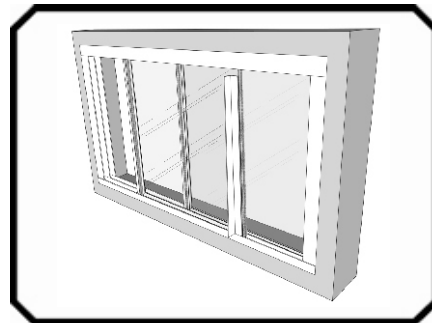

**TrackGlaze**

We can supply a comprehensive choice of cost effective double glazing products, designed for easy installation by any DIY enthusiast, and not requiring any special tools to fit. Each product allows you to insulate your windows against heat loss and draughts, as well as noise.

All EasyFix double glazing systems are suitable for removal re-installation, with some allowing repeated easy access suitable for daily ventilation without removing the entire system.

Remember to draught-proof your windows, doors and openings using EasyFix draught excluders, to enhance the benefits gained by double glazing.

## WHICH DOUBLE GLAZING SYSTEM TO CHOOSE?

Whatever your glazing requirements, there is a system to match. Here is a quick summary of the 8 EasyFix systems, and their main features:

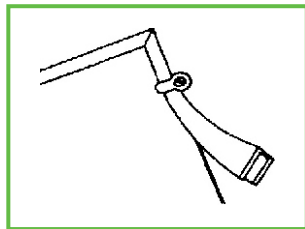

### CLIPGLAZE FLEXIBLE EDGING STRIP

- Low cost solution
- Turnbutton removal
- Screwed to frame
- 3mm to 4.5mm glazing

Flexible edging channel in clear, brown or white which is easily mitred for a neat finish and held in place with the glazing sheet, by nylon clips that are screwed to the window frame. The ClipGlaze system is available in handy 15m kits, or with each component part separate, and is made in 3mm and 4mm channel widths.

This system has been produced and sold continuously for 50 years!

### SUPERGLAZE RIGID EDGING

- Hidden screws
- Smart appearance
- Screwed to frame
- 3mm or 4.5mm glazing

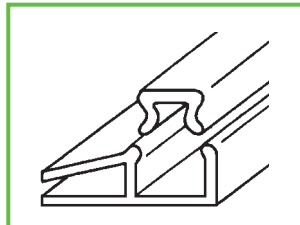

SuperGlaze is a 2 part rigid PVC system suitable for 3mm and 4.5mm plastic sheet. Lengths of extrusion grip the edge of the glazing material before being attached to the window frame/surround with screws. The screws are hidden with a press fit cover strip, and the corners can be mitred for a smart, professional appearance. Available in 2.44m lengths, white or brown.

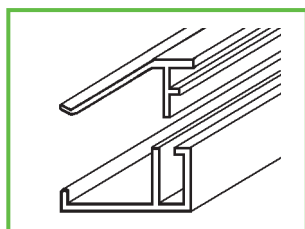

### EASYGLAZE 2 PART RIGID EDGING

- No screws required
- Self-adhesive fixing
- Smart appearance
- 3mm glazing

EasyGlaze is an alternative rigid 2 part DIY glazing system that fixes to the window frame with double sided tape, and after adding plastic glazing sheet, a top section is press fitted to hold it in place and complete the neat and professional appearance. Easyglaze can be mitred to form a frame. Available in 2.44m lengths, white or brown.

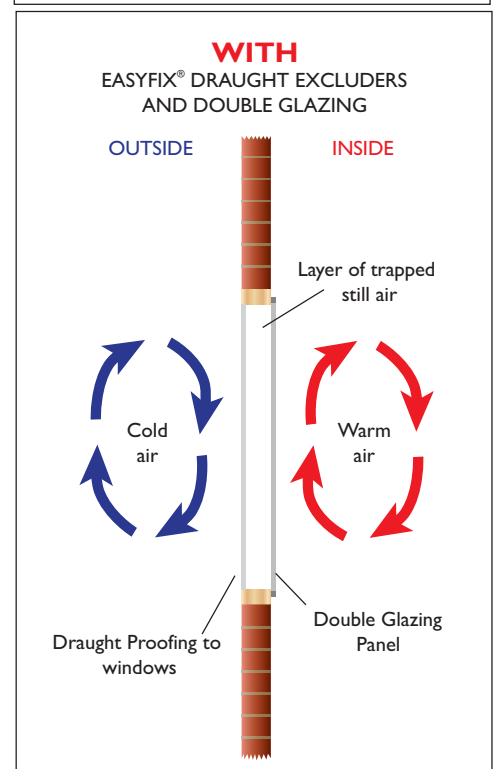
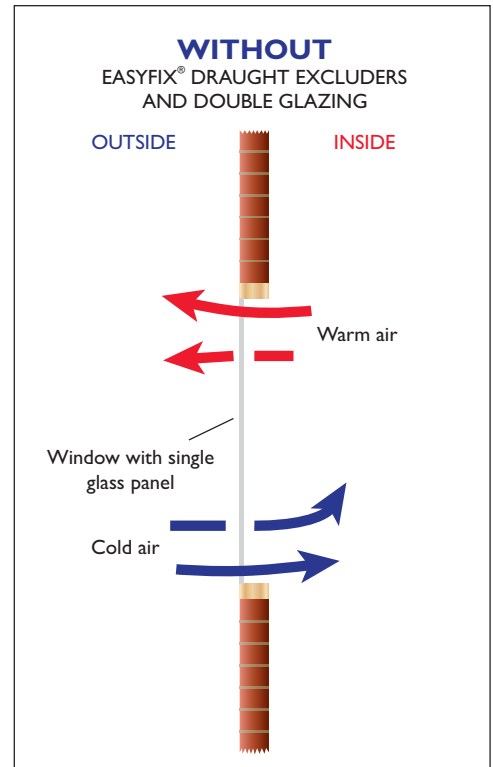

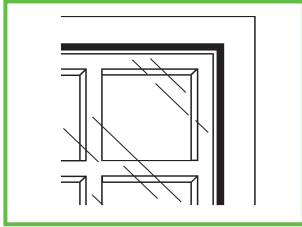

### MAGNETGLAZE MAGNETIC STRIPS

- No screws required
- Steel strip stuck to frame
- Magnetic strip attached to sheet
- 3mm to 4.5mm glazing
- Cosmetic trims available

MagnetGlaze is a quick removal system for plastic sheet. It uses a magnetic strip on the glazing that attaches to a metallic strip on the window surround. This product can be supplied per metre, in 5m kits or 30m bulk rolls in convenient dispensing packs. Easy to use and install, simply lift the panel off the window when access is required. Once fitted, visible parts are white.

### MAGNETGLAZE PRO RIGID EDGING

- No screws required
- Steel strip stuck to frame
- Magnetic strip is attached to plastic sheet edging
- 3mm to 4.5mm glazing
- Neat appearance

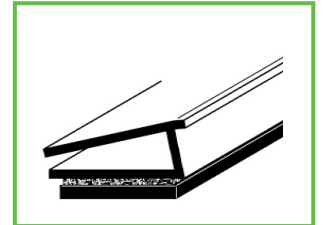

Using the same steel magnetic system as MagnetGlaze, MagnetGlaze Pro has a smart rigid plastic edging that will neatly mitre to frame the glazing sheet but still allowing easy removal. Available in 2.44m lengths, white or brown.



### MAGNETGLAZE SASH MULTI-PANEL KITS

- 2mm plastic sheet only
- Uses basic MagnetGlaze system with extra features
- Repeated removal of glazing sheet possible
- Ideal for sash windows

Specifically designed for sash windows, where daily ventilation and night-time noise and heat insulation are required, MagnetGlaze Sash has a joining strip that allows part of the panel to be removed and stored on the face of the other panel for convenience. Visible components are white.

### TRACKGLAZE SLIDING SYSTEM

- Sliding panel system
- Components are self-adhesive & sticks within window cavity
- Smart and easy to use
- Versatile design for 3mm glazing

TrackGlaze is a smart and easy to install system that gives instant access to your outer windows via simple slide opening. It uses Double Sliding track on all 4 sides of the window cavity, Bristle Seal draught excluder on the edges of each glazing sheet and an Angle for a finger-pull handle. All components are self-adhesive. Packs have 2m or 1m lengths, in white or brown.

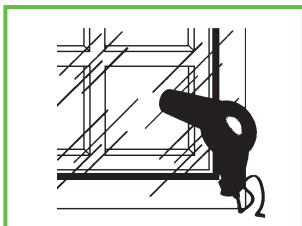
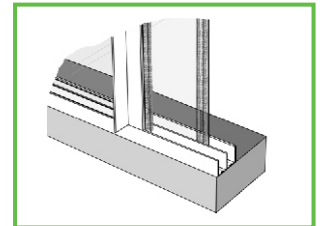

### FILMGLAZE HEAT-SHRINK SYSTEM

- Thermal film
- Self adhesive
- Cost-effective
- Quick to install

FilmGlaze uses a sheet of thermal film that is fixed to the window surround using double sided tape. Once fitted the film is stretched by gentle use of a hairdryer to give effective and low cost winter insulation and draught proofing. Adhesive tape and film are clear / transparent once installed.

## How to Measure Your Windows

### MEASURING FOR:

**CLIPGLAZE, SUPERGLAZE, EASYGLAZE, MAGNETGLAZE & MAGNETGLAZE PRO**

1. For each panel, assign a Label/Code up to 3 characters in length.
2. Each EasyFix Double Glazing system has its own additional clearance to factor in to the finished acrylic panel size. We will take care of this addition. All we need is the measurement between the two points where the flat mounting surface begins. We call these the Standard Measurement Points. Measure the Width and Height for each window.

This measurement should cover the existing glass, rubber/putty beading and any angled edges before the beginning of the flat mounting surface on the outward face of the frame.

### MEASURING FOR:

**HARDWARE / LATCH CUTOUTS**

3. If your windows have latches or other hardware that will obstruct the acrylic double glazing panel, we can supply these panels with cutouts so that the acrylic edge will pass around the hardware without obstruction.
4. The "Cutout Location" refers to which edge of the frame the cutout will be: Top, Bottom, Left or Right.
5. These measurements are to be taken from the same Standard Measurement point, to the beginning of the hardware, and again to end of the hardware. All measurements for Top and Bottom cutouts are taken from the left, and all measurement for Left and Right cutouts, are taken from the bottom.
6. A third dimension is required showing any offset from the opposite Standard Measurement Point. This will determine the depth of the cutout, into the acrylic panel. If the hardware is not flush with the Standard Measurement Point, this is recorded as:
  - A positive measurement for overlapping into the window area.
  - A negative measurement, for a backset away from the window area.

Please see our website to download a measurement template sheet.

Example of window frames and measurement sheet:

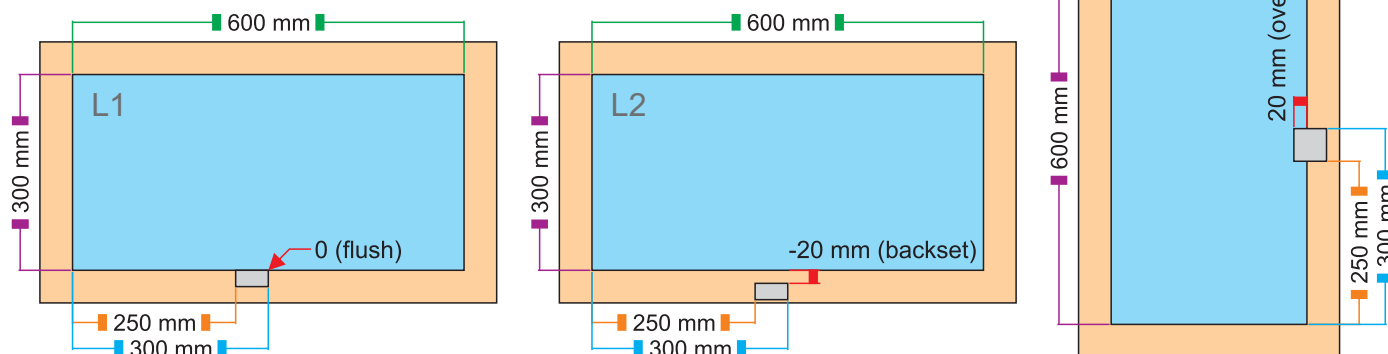

Location	Label (3 char max)	System	Colour	Width	Height	Cutout Location Top / Bottom Left / Right	Dimension 1 (from Left or Bottom)	Dimension 2 (from Left or Bottom)	Dimension 3 Overlap + pos Backset - neg
Lounge	L1	SuperGlaze	White	600	300	B	250	300	0
Lounge	L2	MagnetGlaze	Brown	600	300	B	250	300	-20
Lounge	L3	MagnetGlaze	White	300	600	R	250	300	20

## ClipGlaze Edging Strip

**flexible edging strip held with clips and screws**

ClipGlaze double glazing comprises a flexible PVC edging strip, which is placed neatly around a piece of plastic sheet and held in position by nylon fixing clips and woodscrews. A mitre gauge to help cut neat accurate corners is available separately - a feature unique to our system.

ClipGlaze edging is made for 3mm and 4.5mm plastic sheeting, in clear, brown or white. The edging strip is sold by the metre, nylon clips and screws in packets of 12, and the mitre gauge is sold singly.

Also available are pre-pack kits of 15m that include sufficient clips and screws, a mitre gauge and full fitting instructions in the pre-pack.

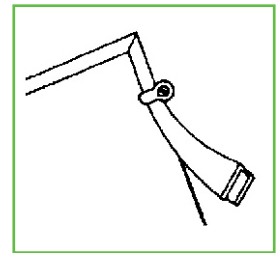
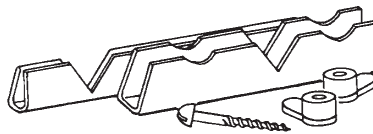

A ClipGlaze secondary pane can be fixed either to the opening window to allow ventilation and use of the window, or to the main frame for maximum insulation and draught proofing.

**HELPFUL HINTS** - The edging strip is always easier to work with when it's warm. We suggest placing it in the airing cupboard or similar place the night before use. When placing edging strip onto your panel **DO NOT** run your finger down the back of the edging strip to apply it quickly, work a few centimetres at a time.

**TOOLS REQUIRED** - A screwdriver, craft knife or similar, ball-point pen and a tape measure.

### Measuring up for your Acrylic panels

Please refer to the How to Measure Your Windows page.

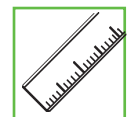

### USING CLIPGLAZE STEP BY STEP

1. Place a mark on the edging strip 5cm from a neat squarely cut end.
2. Lay the edging strip in the channel of the ClipGlaze mitre gauge so the mark on the edging strip is in the centre of the middle "V". Holding the strip firmly in the two finger grips, cut down each side of the "V" with the sharp knife, being careful not to cut right through the strip
3. Now carefully fit the edging strip on the panel, the cut out should mould easily around the first corner. Continue along this edge to the next corner and place a mark with the pen on the edging strip where the panel finishes. This point marks the position of the next corner.
4. Repeat steps 2 and 3 until the edging strip is fitted around the pane of plastic.
5. You will need a clip about 5cm from each corner on each side, then clips spaced equally about 20-25cm along the remaining distance.
6. Position the sheet carefully so there is an equal overlap on the frame on all four sides.
7. Fix the two clips on the bottom edge 5cm from the corners - these will hold the weight of the sheet.
8. Make sure the glass is clean and the window perfectly dry before resting the pane on the bottom fixing clips. Fix two clips on the top edge, making sure that one of these first four clips covers the join in the edging strip.
9. Now complete the window by fixing the rest of the clips as suggested above.

edging strip

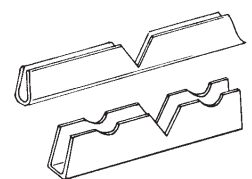

mitre gauge

**PLEASE READ INSTRUCTIONS THOROUGHLY BEFORE CUTTING OR FITTING ANY SYSTEM**



## SuperGlaze System

### a rigid system fixed with screws

The SuperGlaze system comprises a rigid PVC moulding to edge the glass, this being mitred at the corners, which is then fixed to the frame with screws through the open fixing channel. A cover strip is then snapped into place concealing the fixing screws giving a neat, unobtrusive appearance.

SuperGlaze is sold in 2.44m lengths, in white and brown.

The SuperGlaze secondary pane may be fixed either to the opening windows to allow ventilation and use of the windows, or to the main frame for maximum insulation and draught proofing.

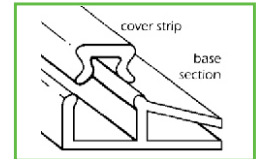

When using SuperGlaze ensure there is at least 20mm of flat mounting surface around each side of the glass to take the fixings.

#### HELPFUL HINTS -

- When applying the base section DO NOT attempt to slide it on, it is easier to start at one end and push on cm by cm.
- For window frames where gaps occur between the base section and the frame when the pane is in position, we recommend the use of our standard PVC foam draught excluder DGDE901. This should be fixed to the bottom of the base section so that when the pane is screwed into place the foam is compressed and forms the seal, this creates the layer of still air needed to provide the insulation.

**TOOLS REQUIRED** - Fine toothed saw, mitre block, tape measure and a screwdriver.

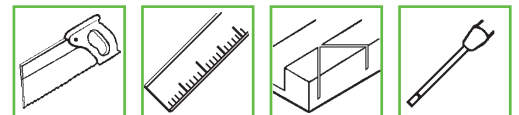

#### Measuring up for your Acrylic panels

Please refer to the How to Measure Your Windows page.

#### Measuring up for your SuperGlaze lengths

- For the sides, take measurement A and add 39mm.
- For the top and bottom, take measurement B and add 39mm

#### USING SUPERGLAZE STEP BY STEP

- Snap cover strip into base section.
- Working with your piece of acrylic, measure the side to which you want to place a strip of SuperGlaze. Add 23mm to this and squarely cut a length of the SuperGlaze to suit. Repeat this step for each side remembering to use the correct lengths for sides, top and bottom.
- Insert a piece of Mitre Bead into the SuperGlaze base profile and using the outer corner as a reference point (see Diagram A), cut a 45° mitre on each end, using the fine toothed saw and mitre block. Repeat this for each length.
- Remove the cover strip and mitre bead and mark base and cover sections on the inside, ready to pair up later.
- Fit base section around the edges of the panel. (see Helpful Hints).
- After cleaning the glass and making sure the window is perfectly dry, offer up the edged pane to the window frame and fix using suitable screws through the holes in the SuperGlaze base section. Use extra screws if necessary to ensure a snug fit all round the frame.
- Replace each cover strip in its base section to complete the system.

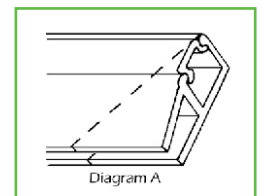

**PLEASE READ INSTRUCTIONS THOROUGHLY BEFORE CUTTING OR FITTING ANY SYSTEM**

## EasyGlaze System

### a rigid self-adhesive system

The EasyGlaze double glazing system comprises two rigid PVC sections, a base section and a cover strip. It is sold in 2.44m lengths, in white and brown. Mitre beading is also supplied to assist you in cutting neat, accurate corners. This product is fixed to the frame by self-adhesive tape which is mounted on the base section.

The EasyGlaze system is for internal use only, fixing directly to the frame for maximum insulation and draught proofing. When using EasyGlaze ensure there is at least 15mm of flat mounting surface around each side of the glass to take the adhesive base section. We recommend using 2mm Clear Acrylic sheet with EasyGlaze.

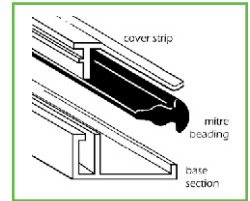

**HELPFUL HINTS** - To achieve a neat mitre, insert a small piece of mitre beading between the base and cover strip at the point where the mitre is to be cut. Cut the mitre through all sections. This beading has the effect of holding the cover strip at the correct angle so that when applied to the sheet it results in a neat mitre.

**TOOLS REQUIRED** - A fine toothed saw, mitre block, pencil and tape measure.

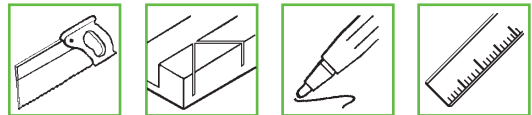

#### Measuring up for your Acrylic panels

Please refer to the How to Measure Your Windows page.

#### Measuring up for your EasyGlaze

1. You will require 2 lengths at measurement A plus 25mm and 2 lengths at measurement B plus 25mm for your window. Add these together to find out how many of each size of lengths you will need.

#### USING EASYGLAZE STEP BY STEP

2. Ensure cover strip is snapped into base section.
3. Working with your glazing panel, measure the side to which you want to place a strip of EasyGlaze. Add 13mm to this and squarely cut a length of the EasyGlaze to suit. Repeat this step for each side.
4. Insert a small piece of mitre beading between cover and base at the end of the length to be cut. Using the outer corner as a reference point (see Diagram B), cut a 45° mitre using the fine toothed saw and mitre block. Repeat this step for each corner.
3. Now place the EasyGlaze onto each edge of the plastic sheet. Hold the panel to the window frame so that it overlaps equally on each edge and make a pencil mark around the panel on the frame.
4. Using a suitable cleaner, such as Easyfix<sup>®</sup> Surface Preparation Wipes, clean the window surround to ensure a grease-free surface, this provides the best results for the adhesion of the tape. Make sure the window is perfectly dry.
5. Remove the EasyGlaze from the panel and separate the base and top sections (mark which top goes with which bottom section). Remove the backing tape and apply the base to the window frame just inside the pencil mark. Check corners are neat and square then press home firmly. (The adhesive is very strong and re-positioning of the pane is not possible).
6. Once all four sides are complete, offer the plastic sheet to the window frame and insert the top section to hold it in place.

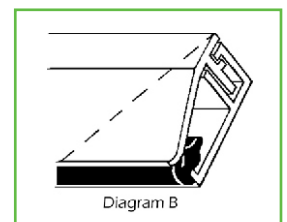

**PLEASE READ INSTRUCTIONS THOROUGHLY BEFORE CUTTING OR FITTING ANY SYSTEM**

## MagnetGlaze System

### a magnetic fixing system

MagnetGlaze is a popular and easy to use system within the Easyfix range. It comprises two strips, one metal and the other magnetic. The metal strip is white faced and has self-adhesive tape on one side. This strip is placed on the window frame around the area to be glazed. The magnetic strip, which is also self-adhesive is placed around the edges of the plastic sheet.

MagnetGlaze is available to purchase by the metre, and as a 5m pre-pack or a 30m dispenser pack.

MagnetGlaze is intended for internal use only.

**ADD-ONS AVAILABLE** - see [awardplastics.co.nz](http://awardplastics.co.nz) or ask your stockist.

- Make MagnetGlaze into 2 or more panels with MagnetGlaze Sash kits that use a specially designed joiner strip that maintains the thermal seal between panels.
- Hide the glazing sheet edges and the magnetic strip with attractive MagnetGlaze Finishing Trim: a self-adhesive white strip that is easy to mitre and install for a professional finish.

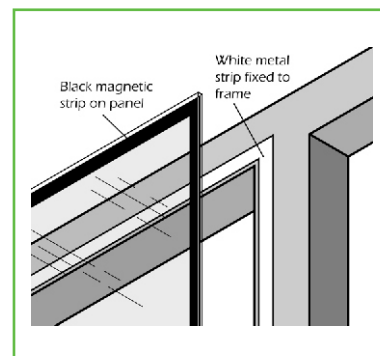

**HELPFUL HINTS** - For larger windows (1200mm x 1200mm or bigger) we recommend placing a couple of screws under the glazing panel to support the sheet. This will remove the risk of the sheet from moving downwards and becoming detached.

**TOOLS REQUIRED** - Tape measure, pencil and a strong pair of scissors.



#### Measuring up for your Acrylic panels

Please refer to the How to Measure Your Windows page.

#### Measuring up for your MagnetGlaze

1. You will require 2 lengths at measurement A plus 25mm and 2 lengths at measurement B for your window (do not add 25mm to measurement B). Add these together to find out how much MagnetGlaze you will need.

#### USING MAGNETGLAZE STEP BY STEP

2. Now clean and degrease the window surround using a suitable cleaner, such as Easyfix Surface Preparation Wipes for best adhesion results.
3. Remove strips from packaging and begin by cutting and sticking the black magnetic strip to each edge of the plastic sheet.
4. Hold the sheet up to the window frame and draw a pencil line around the sheet.
5. Cut and fit the white metal strip to the window frame, sticking it just inside the pencil marks.
6. Offer up the glazing panel to the window and align the magnet with the steel strip.

**PLEASE READ INSTRUCTIONS THOROUGHLY BEFORE CUTTING OR FITTING ANY SYSTEM**



## MagnetGlaze Sash

### a magnetic fixing system for sash windows

The MagnetGlaze Sash kit is an add-on to the popular and easy-to-use Easyfix MagnetGlaze system, with extra components specifically designed to work with sash windows, or any windows where frequently used part panels are required. Instead of a single panel covering the whole window, MagnetGlaze Sash uses a flexible jointing strip so that 2 or more panels can be used while still maintaining a thermal seal. For example, on a sash window, the top panel can easily be removed for ventilation and be quickly refitted at night to reduce external noise. When removed, one panel can be clipped onto another using additional steel tape, and the static panel can be supported or kept in place using turn buttons if desired.

Much simpler and more cost effective than other sash insulation products, MagnetGlaze Sash allows heat and noise insulation alongside the convenience of normal use of the window. It can be retrofitted to existing MagnetGlaze installations or used for first-time secondary glazing projects.

MagnetGlaze Sash is for 2mm plastic sheet only and the Sash kit must be used in addition to the MagnetGlaze system.



**TOOLS REQUIRED** - Tape measure, pencil and a strong pair of scissors.

#### Measuring up for your Acrylic panels

Please refer to the How to Measure Your Windows page.

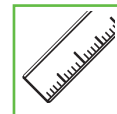

#### USING MAGNETGLAZE SASH - STEP BY STEP

1. Thoroughly clean and de-grease the window surround using Easyfix Surface Preparation Wipes.
2. Cut and stick the black magnetic strip to the 3 edges of the glazing panel that will be stuck to the window frame, repeat this step for both panels.
3. On the sheet that will NOT be removed as often, measure the gap on the open side between the magnetic strips and cut a length of the flexible H section to this size.
4. Stick the adhesive tape onto the sheet between the magnetic strips, immediately next to the edge and position the H section length over it. Make sure the narrow face is at the front.
5. Remove the self-adhesive backing from under the H section and press firmly into place.
6. Hold the jointed sheet up to the window and draw a pencil line around the edge of the sheet onto the window frame.
7. Carefully cut and fit the white metal strip to the window surround, sticking it just inside the pencil line.
8. Select the panel with the H section attached and offer this to the window and click into place. Holding the other panel at an angle, insert the edge into the H section and gently push the panel onto the metal strip.
9. Stick white metal strips around the front face of the static panel covering the magnetic tape below. Fix this to the edges so that the other panel, when removed, can be placed onto this for easy storage.

**Please note:** When removing one panel from the other it is possible to dislodge both. To avoid this, turn button clips can be placed under the bottom panel to support it and help prevent slippage. Clips can be positioned elsewhere, as required, but make sure the removable panel can still clip into place as necessary.

**PLEASE READ INSTRUCTIONS THOROUGHLY BEFORE CUTTING OR FITTING ANY SYSTEM**

## MagnetGlaze Pro System

### a rigid framed magnetic fixing system

MagnetGlaze Pro combines the simplicity of the magnetic fixing with the aesthetic appeal of framing your plastic sheet. It comprises two parts, a rigid pvc frame profile which has the magnetic strip attached and a self-adhesive metal strip. Mitre beading is also supplied to assist you in cutting neat, accurate corners. This system is particularly suitable for windows requiring quick or repeated removal.

MagnetGlaze Pro is sold in 2.44m lengths, in white or brown.

MagnetGlaze Pro is intended for internal use only.

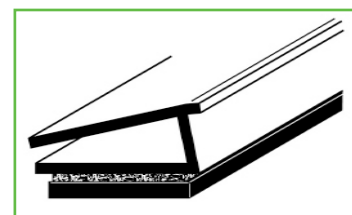

**HELPFUL HINTS** - For larger windows (1200mm x 1200mm or bigger) we recommend placing a couple of screws under the glazing panel to support the sheet. This removes the risk of the sheet slipping downwards and becoming detached.

**TOOLS REQUIRED** - Fine tooth saw, tape measure, mitre block and pencil.

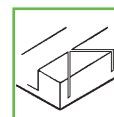
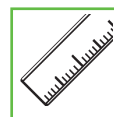
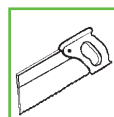

#### Measuring up for your Acrylic panels

Please refer to the How to Measure Your Windows page.

#### Measuring up for your MagnetGlaze Pro

1. You will require 2 lengths at measurement A plus 33mm and 2 lengths at measurement B plus 33mm for your window. Add these together to find out how many lengths of each size you will need.

#### USING MAGNETGLAZE PRO STEP BY STEP

- Using a suitable cleaner, such as Easyfix Surface Preparation Wipes, clean the window surround to ensure a grease-free surface, this provides the best results for the adhesion of the tape.
- Remove the white metal strip from the length of MagnetGlaze Pro.
- Working with your plastic panel, measure the side to which you want to place a strip of MagnetGlaze Pro. Add 3mm to this and squarely cut a length of MagnetGlaze Pro to suit. Repeat for each side of the panel.
- Using the outer corner as a reference (see diagram), insert the mitre bead and cut a 45° mitre using the fine toothed saw and mitre block. Repeat this step for all lengths.
- Now fit the MagnetGlaze Pro to the edges of the panel.
- Hold the panel to the window frame so that it overlaps equally on each edge.
10. Draw a pencil line around the sheet on the frame.
- Cut and fit the white metal strip to the window frame, sticking it just inside the pencil marks.
- Offer up the glazing panel to the window and click into place.

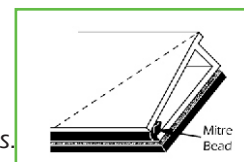

**PLEASE READ INSTRUCTIONS THOROUGHLY BEFORE CUTTING OR FITTING ANY SYSTEM**

## FilmGlaze System

### a simple yet effective film system

FilmGlaze is the simplest double glazing system in the Easyfix range. It comprises a sheet of film and a roll of double-sided adhesive tape. The tape is placed around the area to be glazed, the plastic film is then carefully stuck to it and a hairdryer is used to stretch the film. Any wrinkles and creases showing will simply vanish as the heat is applied. Although the cheapest, it is still an effective means to double glaze your windows.

FilmGlaze is available in 9.0m<sup>2</sup> packs.

Comprehensive fitting instructions and Surface Preparation Wipes are included in each pack. The actual film size is 1.5m wide and 6.0m in length.

FilmGlaze can be used on individual windows, or over the complete window area. Handles and locks can be removed and replaced after the film has been applied. Being a simple film it allows for quick access in cases of emergency.

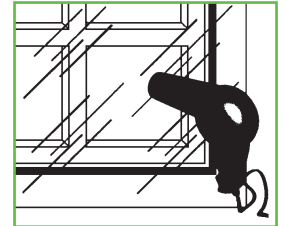

**TOOLS REQUIRED** - Sharp craft knife and an ordinary hairdryer.



**HELPFUL HINTS** - Use the film at room temperature and make sure you are only using a single layer. Do not touch the adhesive with your fingers as this may affect the bonding to the frame or film. Try to apply the film as evenly as possible before using the hairdryer.

#### USING FILMGLAZE STEP BY STEP

1. Using a sachet of the wipes provided, thoroughly clean the frame to remove any grease marks or polish. Painted frames must be in good condition to give maximum effect. Remember to clean the window at this stage.
2. Apply the double-sided tape to the window frame allowing it to overlap at each end. Once all four sides have been completed trim off excess tape from each corner. DO NOT remove the backing paper yet. Using a soft cloth, press firmly on the tape to ensure adhesive has made proper contact with frame.
3. Completely unfold the glazing film supplied so that you are using only a single layer of film. Offer the film up to the window and mark or cut to the required size. Remember to allow enough material to trim off once film has been secured.
4. Remove the backing paper from the double-sided tape at the top of your window frame. Holding the film by the top corners apply to the tape keeping the film as flat and taut as possible. Remove the other three pieces of backing paper from your frame. Holding the bottom corners apply the film to the adhesive tape in the same way. If large wrinkles are noticeable, the film can be carefully removed and repositioned. Once in place apply pressure over the film and tape to secure edges of the FilmGlaze system.
5. Using an ordinary hairdryer on the lowest heat setting begin heating the film at the top left corner and work towards the bottom right. If the film does not appear to be shrinking, move the hairdryer closer, between 2 - 5 cm from the film is ideal. If this still does nothing it will be necessary to change your hairdryer to a higher heat setting. The wrinkles and creases will disappear and leave a clear, economical and effective double glazed unit. To test the film is tight enough, leave for approximately 30 seconds and then tap film with a finger, you should hear a tight drum sound.
6. Using a very sharp knife trim off all excess film from around the outside of the tape to leave a neat, unobtrusive sealed unit.

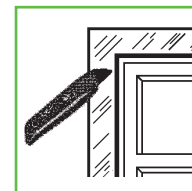
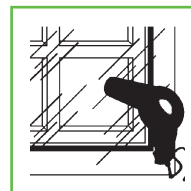
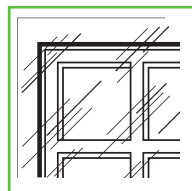
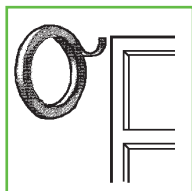

FilmGlaze can be kept clean by wiping with a soft cloth. If too much pressure is applied and the film goes saggy, it can be tightened again using the hairdryer. When the time comes to remove the film, carefully trim just inside the tape and remove the centre panel of film. With the help of the hairdryer, warm and ease the double-sided tape away from the frame. Any adhesive left behind can be cleaned using an Easyfix Surface Preparation Wipe or an alternative cleaner.

## HELPFUL HINTS

The window cavity to be insulated must be flat and true, i.e. the same height all along to allow the glass to slide, and the cavity cannot be sloping.

If you have more than one opening window behind TrackGlaze, or purely for aesthetics, it is possible to have a static panel in the rear track and two sliding panels in the front track, at either side of the rear panel. This is no more difficult to achieve, but double check glazing sizes before purchase to make sure sufficient overlap has been allowed.

TrackGlaze has been designed for use without mitred corners, because the differing heights of the top and bottom track make 45° mitres unfeasible. If you wish to attempt them you will need to adjust the lengths required and we strongly recommend that you do a trial fit of any mitred corners before removing the adhesive tape backing.

## TOOLS REQUIRED

- Fine tooth saw, pencil, tape measure, and a pair of scissors.

### Measuring up for your Acrylic panels

1. TrackGlaze is a unique system which is mounted on the inner face of the window cavity, NOT on the interior facing surface of the window frame.

The measurements required for this system are the width and height of the window cavity.

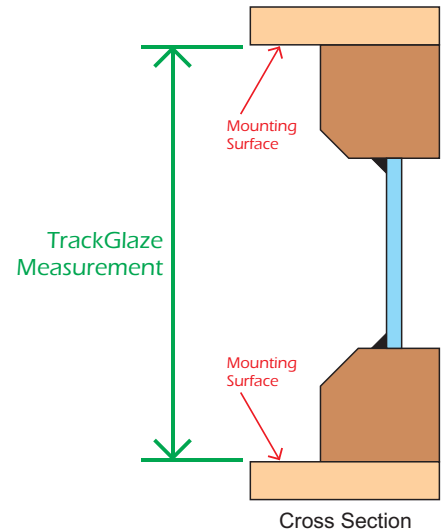
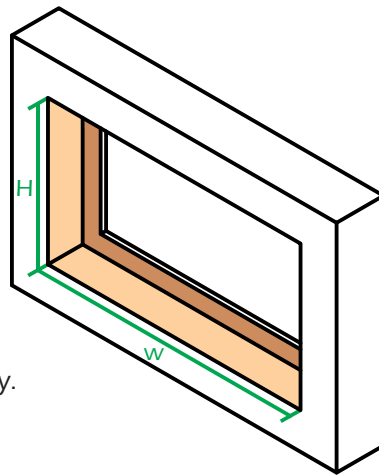

### Measuring up for your TrackGlaze lengths

2. For the frame bottom, you need one length of Bottom Track cut to measurement W. For the rest of the frame, you need lengths of Top Track as follows: one cut to measurement W, two cut to measurement H less 25mm.
3. For the finger pull handle, the maximum length would be measurement H less 35mm. It will work perfectly if it is shorter, but it is also useful for masking the Bristle Seal where the glazing panels meet.

## USING TRACKGLAZE STEP BY STEP

4. Clean and degrease the window frame where TrackGlaze is to be fitted, e.g. with Easyfix Surface Preparation Wipes.
5. Cut a length of bottom track (the shallow track) to measurement W, and fit to the bottom of the frame. Cut a length of top track to measurement W and fit to the top of the frame.
6. Check the exact measurement between the top and bottom tracks - this should be approximately measurement B less 25mm. Cut two lengths to the exact measurement and fit to the window frame sides. The tracks should neatly align all the way round.
7. Working with the rear panel first, cut exact lengths of Bristle Seal and fit to all 4 edges of the glazing panel, on the same face, within 1mm of each edge. Insert the panel into the rear track with the Bristle Seal facing towards you. This is done by pushing the panel up into the deeper top track, lifting over the lip of the shallow bottom track and placing into the rear channel of the bottom track.
8. Now working with the front panel, cut exact lengths of Bristle Seal and fit to the 3 sides that will be enclosed by the track - avoid fixing to the edge where the panels overlap. Trial fit the front panel with the Bristle Seal facing away from you. With the panels in the closed position, make sure the final Bristle Seal will match up with the seal on the rear panel. Remove the front panel and install the last length of Bristle Seal and then replace the panel.
9. Measure the visible height of the glazing and subtract 10mm (to allow each panel to be lifted out when required) Cut this length of Angle and apply to the visible edge of each panel in the front track, leaving the 10mm gap at the top. This should mask the Bristle Seal behind it and allow easy sliding of the panels. An optional length of angle can be fitted to the rear panel if required.
10. Slide the panels into the closed and sealed position.

**PLEASE READ INSTRUCTIONS THOROUGHLY BEFORE CUTTING OR FITTING ANY SYSTEM**

Award Plastics  
& Displays

7 William Lewis Drive, Sockburn, Christchurch 8042  
easyfix@awardplastics.co.nz ~ 0800 426 292 ~ www.awardplastics.co.nz

Easyfix® is a registered trademark of Tubeway (Sales) Limited, manufacturers and distributors in the UK.



## TrackGlaze System

### the easy access sliding insulation system

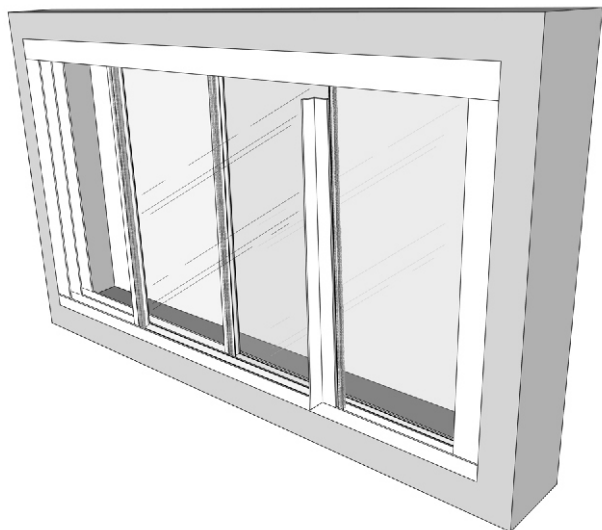

TrackGlaze is an easy to install system that gives you excellent heat and noise insulation, with the advantage of simple slide opening for access to your outer windows. The system comprises rigid PVC Double Sliding Track, that is used on all 4 sides of the window cavity, Bristle Seal draught excluder for the edges of the glazing sheets and a simple rigid PVC Angle for the finger pull handle on the glazing panels. The finished appearance is smart and clean, and the draught excluder ensures that every part of the frame is sealed when closed. Installation is made simple by the self-adhesive tape which is on every component, and the track lengths can be strengthened with other appropriate fixings if required.

The TrackGlaze Sliding Tracks are cleverly designed so they can be fully fitted to the window cavity BEFORE inserting the glazing sheet, using the steps below.

- By pushing the sheet up into the deeper top track,
- Lifting the sheet over the lip of the shallower bottom track,
- Placing into the correct channel, leaving the top of the sheet still contained in the top track.

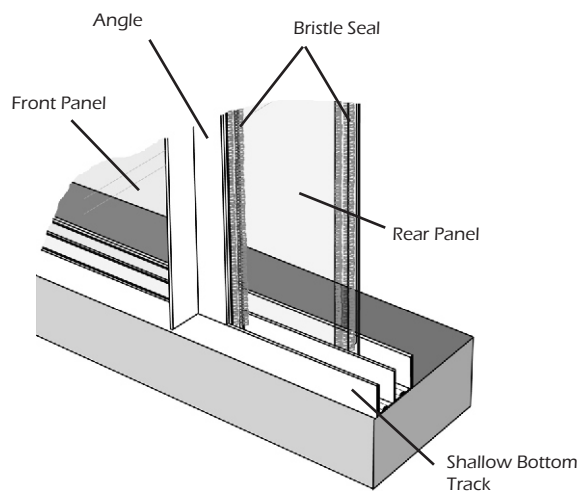
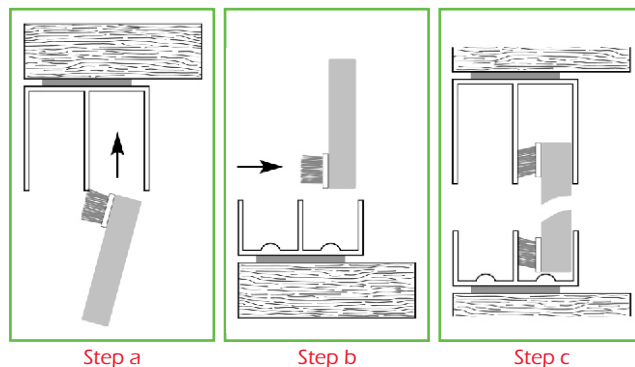

Bottom of Window Frame

Easyfix DIY TrackGlaze is designed for use with 3 - 4.5mm plastic sheet. It is supplied fully packaged, including fitting instructions, with the following self-adhesive contents in each retail pack:

- 3 lengths Top Sliding Track
- 1 length Bottom Sliding Track
- 2 lengths Angle
- 1 coil of Bristle Seal

Packs also contain Easyfix Surface Preparation Wipes, which clean and degrease the window surround to give best adhesion of the self-adhesive tape. They are sold in either 1m or 2m pre-packs with 6m or 12m of Bristle Seal and available in all white or all brown, although the completed frame can be painted if required.

**SIZE RESTRICTIONS** - We recommend that panels are limited to 1000mm on either dimension to ensure the panel is not too heavy to install or slide, also to reduce the risk of bowing. The angle handles placed on both sides will also help prevent this. Please note the ideal shape for glazing panels is wider than taller, for stability when sliding.



## ClipGlaze Edging Strip

flexible edging strip held with clips and screws

Stock code	Description	Colour	Price (Incl. GST)
DG300	3mm Edging Strip	Clear	\$2.59/mtr
DG305	3mm Edging Strip	Brown	\$2.59/mtr
DG340	3mm Fixing Clips	Natural	\$4.49 /12 Pack
DG345	3mm Fixing Clips	Brown	\$4.49 /12 Pack
DG400	4mm Edging Strip	Clear	\$3.68 /mtr
DG405	4mm Edging Strip	Brown	\$3.68 /mtr
DG440	4mm Fixing Clips	Natural	\$4.49 /12 Pack
DG445	4mm Fixing Clips	Brown	\$4.49 /12 Pack
DG700	Wood Screws Bright Zinc 12pk	Silver	\$2.53 /12 Pack
Dg710	Mitre Gauges	Black	\$1.56 ea
DGP50B	3mm Prepack Kit 15m	Brown	\$84.64
DGP50C	3mm Prepack Kit 15m	Clear	\$84.64
GP305W	3mm Prepack Kit 5m	White	\$35.94
DGP51B	4mm Prepack Kit 15m	Brown	\$91.20
DGP51C	4mm Prepack Kit 15m	Clear	\$91.20
GP405W	4mm Prepack Kit 5m	White	\$44.51

## SuperGlaze System

a rigid system fixed with screws

Stock code	Description	Colour	Price (Incl. GST)
DGSG30	SuperGlaze 915mm Length	White	\$11.50
DGSG35	SuperGlaze 915mm Length	Brown	\$11.50
DGSG40	SuperGlaze 1220mm Length	White	\$15.18
DGSG45	SuperGlaze 1220mm Length	Brown	\$15.18
DGSG80	SuperGlaze 2440mm Length	White	\$17.25
DGSG85	SuperGlaze 2440mm Length	Brown	\$17.25
DGSGMB01	Mitre Cutting Block Black	Black	\$13.80

## MagnetGlaze Sash

a magnetic fixing system for sash windows

Stock code	Description	Colour	Price (Incl. GST)
DGMGS-H-1M	MagnetGlaze Sash H-Joiner	White	\$5.29 /mtr
DGMGS-STEEL-1M	MagnetGlaze Extra Steel	White	\$7.13 /mtr
DGMGS04W	MagnetGlaze Sash Heavy Duty Kit	White	\$161.00
DGMGS04B	MagnetGlaze Sash Heavy Duty Kit	Brown	\$161.00

## MagnetGlaze System

a magnetic fixing system

Stock code	Description	Colour	Price (Incl. GST)
DGMG05	MagnetGlaze 5m Pack		\$62.60
DGMG30	MagnetGlaze 30m Dispenser		\$280.00
DGMGFT05	MagnetGlaze Finishing Trim 5m	White / Brown	\$20.00
DGMGX44	MagnetGlaze Extreme Roll 10 meters		\$200.00
DGMGXFT05	MagnetGlaze Extreme Finishing Trim 5m	White / Brown	\$27.50
	Surface Preparation Wipe x10 pack		\$5.00

## MagnetGlaze Pro System

a rigid framed magnetic fixing system

Stock code	Description	Colour	Price (Incl. GST)
DGMG80	MagnetGlaze Pro 2440mm Length	White	\$37.95
DGMG85	MagnetGlaze Pro 2440mm Length	Brown	\$37.95
DGMGP-CORNER-KIT-W DGMGP-CORNER-KIT-B	MagnetGlaze Pro Corner Cover Kit	White / Brown	\$9.20
DGMG810W	MagnetGlaze Pro 10x 2440mm Pack	White	\$341.55
DGMG810B	MagnetGlaze Pro 10x 2440mm Pack	Brown	\$341.55
DGSPW01	Surface Preparation Wipe x10 pack		\$5.75

## MagnetGlaze Pro Extreme System

a magnetic fixing system

Stock code	Description	Colour	Price (Incl. GST)
DGMGX80	MagnetGlaze Pro Extreme 2440mm Length	White	\$58.19
DGMGX85	MagnetGlaze Pro Extreme 2440mm Length	Brown	\$58.19
DGMGX806W	MagnetGlaze Pro Extreme 6x 2440mm Pack	White	\$314.23
DGMGX806B	MagnetGlaze Pro Extreme 6x 2440mm Pack	Brown	\$314.23
DGMGPE-CORNER-KIT-W	MagnetGlaze Pro Extreme Corner Cover Kit	White	\$10.93
DGMGPE-CORNER-KIT-B	MagnetGlaze Pro Extreme Corner Cover Kit	Brown	\$10.93
DGSPW01	Surface Preparation Wipe x10 pack		\$5.75

## EasyGlaze System

a rigid self-adhesive system

Stock code	Description	Colour	Price (Incl. GST)
DGEG80	EasyGlaze 2440mm Length	White	\$ 13.80
DGEG85	EasyGlaze 2440mm Length	Brown	\$ 13.80
	EasyGlaze will discontinue once stock depleted		
DGSPW01	Surface Preparation Wipe x10 pack	White	\$5.75

## FilmGlaze System

a simple yet effective film system

Stock code	Description	Colour	Price (Incl. GST)
Fg180	Small 1.5m x 1.2m (1.8m <sup>2</sup> )	Clear	\$ 13.97
DGFG450	Med 1.5m x 3m (4.5m <sup>2</sup> )	Clear	\$23.00
DGFG900	Large 1.5m x 6m (9m <sup>2</sup> )	Clear	\$46.00
DGFG001	Extra Self Adhesive Tape 8m Roll		\$6.90
DGSPW01	Surface Preparation Wipe x10 pack	White	\$5.75

## TrackGlaze System

the easy access sliding insulation system

Stock code	Description	Colour	Price (Incl. GST)
DGTG10W	TrackGlaze 1m Kit	White	\$80.50
DGTG20W	TrackGlaze 2m Kit	White	\$ 138.00
DGTG20B	TrackGlaze 2m Kit	Brown	\$ 138.00
DGSPW01	Surface Preparation Wipe x10 pack	White	\$5.75
DGTGV20W	TrackGlaze Vertical	White	\$ 107.96
DGSPW01	TrackGlaze Vertical	Brown	\$ 107.96

## STANDARD VINYL FOAM DRAUGHT EXCLUDER

PVC Foam in rectangular coiled selfadhesive strips, designed to be stuck to the frame of a door or window, which when closed against it forms an airtight barrier. The Standard Vinyl Foam excluder is 7mm wide and 4mm thick, suitable for closing gaps of 1-3mm.

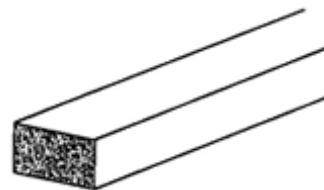

Stock code	Description	Colour	Price (Incl. GST)
DGDE901	Standard Vinyl Foam 5m Roll	White	\$8.74
DGDE902	Standard Vinyl Foam 15m Roll	White	\$12.54
DGDE903	Standard Vinyl Foam 5m Roll	Brown	\$8.74
DGDE904	Standard Vinyl Foam 15m Roll	Brown	\$12.54

## SUPER VINYL FOAM DRAUGHT EXCLUDER

PVC Foam in larger 12mm x 7.5mm size, that will close gaps of 3mm to 7mm. Supplied in self- adhesive coils.

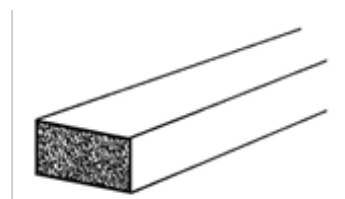

Stock code	Description	Colour	Price (Incl. GST)
DGDE921	Super Vinyl Foam 5m Roll	White	\$14.95

## DELUXE CELL FOAM DRAUGHT EXCLUDER

Cellular Foam supplied in self-adhesive coils, for window and door frames, that has a greater resistance to UV light than Vinyl Foams. This product is 9mm wide x 4mm thick and will seal gaps of 1mm to 4mm.

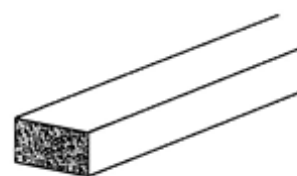

Stock code	Description	Colour	Price (Incl. GST)
DGDE918	Deluxe Cell Foam 5m Roll	White	\$9.32
DGDE919	Deluxe Cell Foam 5m Roll	Brown	\$9.32



## WEATHERSEAL FOAM DRAUGHT EXCLUDER

The ultimate heavy duty closed cell PVC Foam that forms a waterproof barrier when compressed by more than 30%. It is made to continue working in -40 to +70 degrees C temperatures, is rot proof, tough and long lasting, resists sunlight, water, brine, weak acids and alkalis. This draught, dirt, noise and water excluder has multiple uses:

- Home - for work surfaces, freezer or fridge gasket, window extractor fans and door sills
- Caravan or Boat - on roof lights, hatches, doors, windows and ventilators
- Car Exterior - to seal bonnet, door, boot or tailgate
- Car Interior - around car radio, CD and speakers
- Garage - on the wall to protect car doors opening against it
- Other - will prevent telephones and ornaments sliding on polished surface:

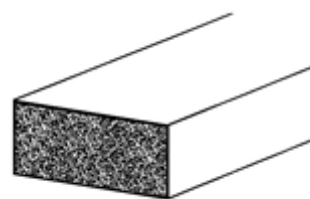

The Super Weatherseal is 15mm wide x 7.5mm thick, and seals gaps of 3mm to 7mm.  
Weatherseal is 9mm wide by 4.5mm thick and seals gaps of 2mm to 4mm.

Stock code	Description	Colour	Price (Incl. GST)
DGDE950	Super Weatherseal 3.5m Roll	Black	\$14.26
DGDE955	Weatherseal 5m Roll	Black	\$12.88

## EPDM E STRIP DRAUGHT EXCLUDER

EPDM is a synthetic rubber with outstanding heat, ozone and weather resistance. These draught excluders are designed to be placed on the frame of a door or window which is then closed against it. Each individual pack comprises 2 x 2.5m strips, coiled together, with self-adhesive backing. Preparation and fitting instructions are included.

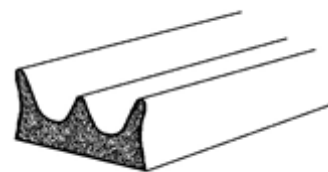

Stock code	Description	Colour	Price (Incl. GST)
DGDE906	EPDM E Strip 5m Roll	White	\$14.26
DGDE907	EPDM E Strip 5m Roll	Brown	\$14.26
DGDE910	EPDM E Strip 5m Roll	Black	\$14.26

## EPDM P STRIP DRAUGHT EXCLUDER

As with the E Strips, EPDM P Strips are designed to stick to a window or door frame which when closed compresses the strip to exclude draughts. Individual packs contain 2 x 2.5m strips with self-adhesive applied. Fitting and preparation guidance is included.

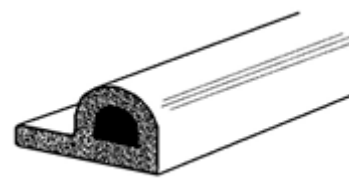

Stock code	Description	Colour	Price (Incl. GST)
DGDE908	EPDM P Strip 5m Roll	White	\$ 14.95
DGDE909	EPDM P Strip 5m Roll	Brown	\$ 14.95
DGDE911	EPDM P Strip 5m Roll	Black	\$ 14.95

## BRISTLE SEAL DRAUGHT EXCLUDER

Simple self-adhesive strips with nylon bristle 5mm high x 4.5mm wide, which are ideal for sealing 3mm to 4mm gaps involving sliding movement, e.g. sash windows and sliding doors.

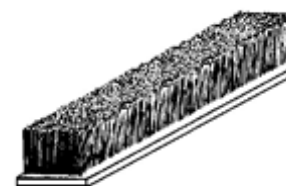

Stock code	Description	Colour	Price (Incl. GST)
DGDE931	Bristle Seal 5m Roll	White	\$20.93
DGDE933	Bristle Seal 5m Roll	Brown	\$20.93

## ACRYLIC SHEET

Acrylic sheet used as the secondary panel for your double glazing. The sheet is optically clear and has a 30 year guarantee against discolouring.

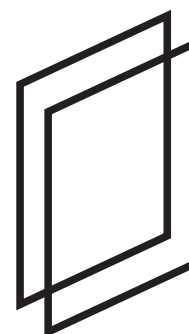

Thickness	Price (Incl. GST) per Square Metre
3.0 mm	\$97.30
4.5 mm	\$138.02

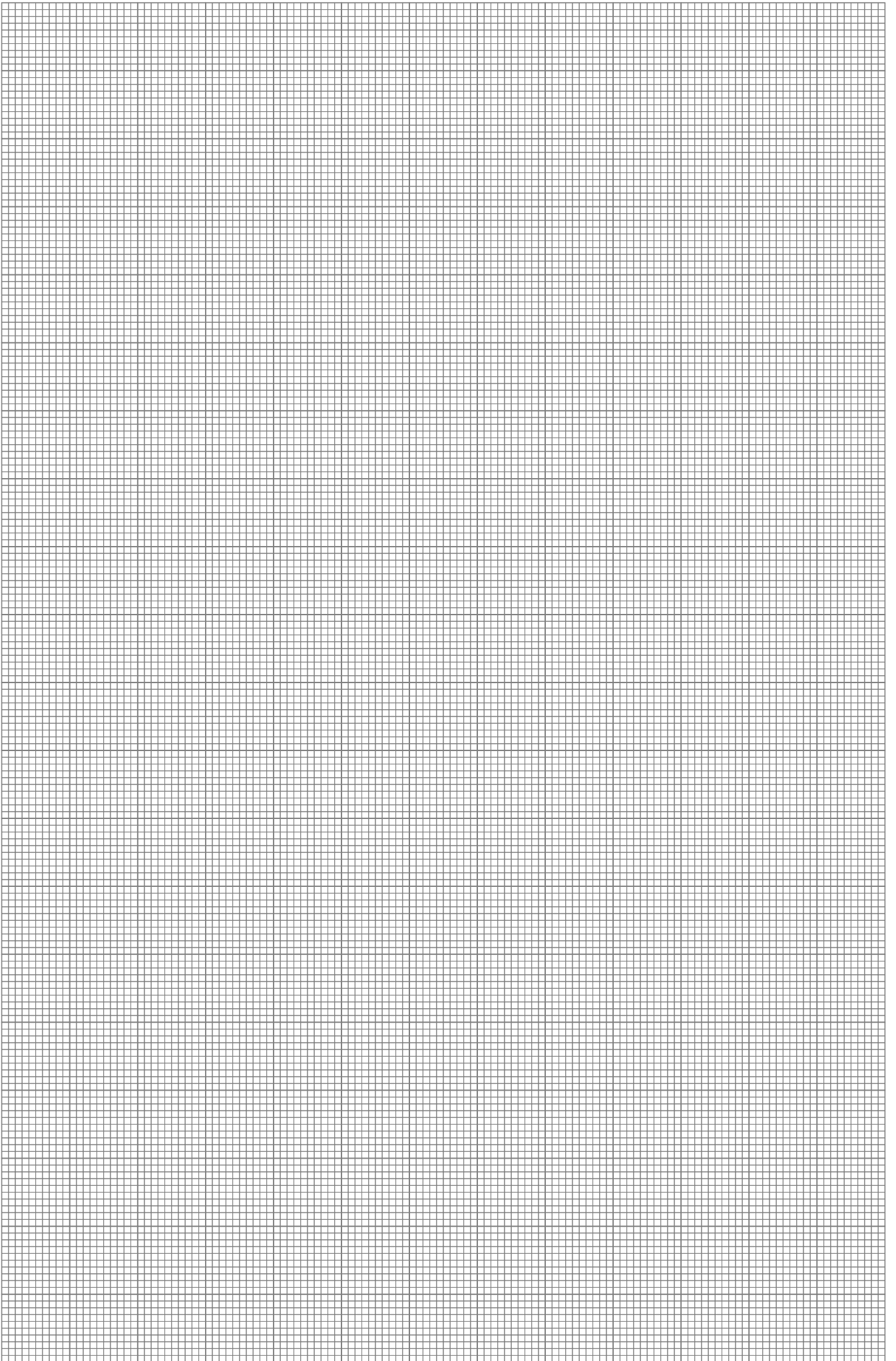

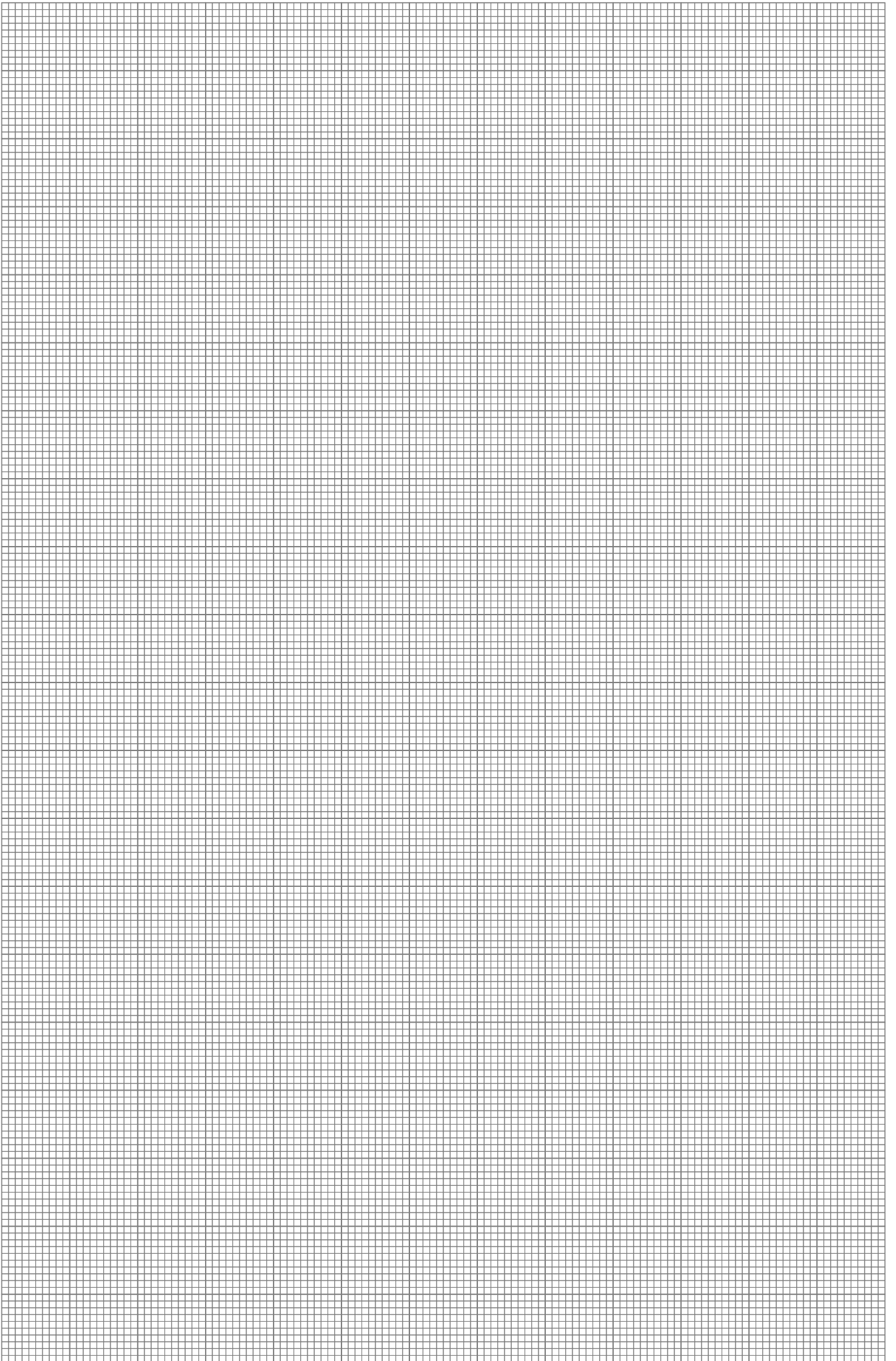

**easyfix**<sup>®</sup>  
*diy* / *products*

Award Plastics  
& Displays

7 William Lewis Drive, Sockburn, Christchurch 8042

[easyfix@awardplastics.co.nz](mailto:easyfix@awardplastics.co.nz)  
[www.awardplastics.co.nz](http://www.awardplastics.co.nz)  
0800 426 292